

# Strength Training for Adults

## Introduction

Strength training involves activities that build and strengthen your muscles. Different exercises work on different muscles. A good strength training program will involve all your major muscle groups (figure 1).

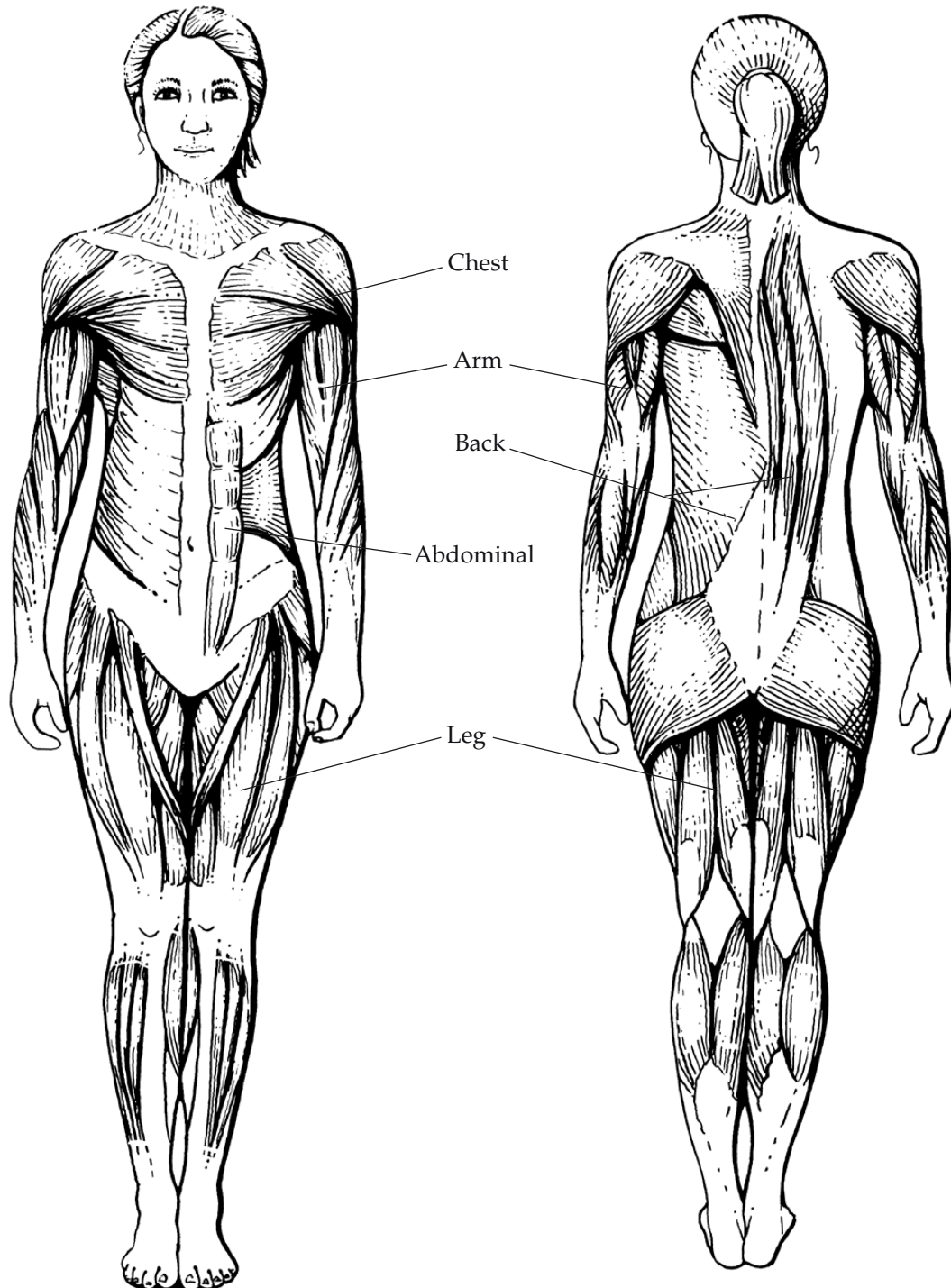

Figure 1. Major muscle groups (abdominal, leg, chest, back, arm)

The purpose of this material is to inform you of general guidelines to be followed in a strength training program, inform you of the benefits of strength training, answer frequently-asked questions about strength training and show you simple exercises that you can do to begin a strength training program.

## *Guidelines*

In order to get the maximum benefit from strength training exercises, it is necessary to follow a few simple guidelines. The exercises and guidelines included here are intended for use by healthy adults. However, before beginning any exercise program, consult your physician.

### **General population**

These guidelines may help you establish a successful strength training program:

- Before beginning your strength training exercises, warm up your muscles.
- Remember to breathe as you exercise. **Do not hold your breath. Inhale through easy moves and exhale through hard moves.**
- Begin your program with 8 to 12 repetitions per exercise. When you are able to perform 12 repetitions of an exercise easily, you may wish to increase the weight.
- Use slow and controlled movements while you exercise.
- Go through the full range of motion of the joint you are exercising.
- Do your strength exercises two or three days per week.
- Allow 48 hours of rest between strength training workouts.
- Have a partner present for safety when necessary.
- Include exercises for major muscle groups in your program.

### **Older adults**

Your age should not keep you from a strength training program. If you are healthy, there are many reasons why a program of strength training exercises may benefit you. Check with your physician before beginning any exercise program.

These guidelines may help you establish a successful strength training program:

- Learn the proper techniques for each strength training exercise you do.
- Use moderate to minimum resistance for the first few weeks of your program.
- Increase repetitions instead of the amount of weight. Do a maximum of 20 repetitions.
- Remember to breathe as you exercise. **Do not hold your breath. Inhale through easy moves and exhale through hard moves.**
- Use slow and controlled movements while you exercise.
- Do your strength exercises two to three days per week.
- Realize that heavy lifting too soon in your program or using improper lifting technique may cause damage to muscles or joints.

If you have arthritis-related pain and/or inflammation, consult your physician about your exercise program. Low- or no-impact exercises may be tolerated and isometric strength training (straight leg raises) may help you preserve your muscle mass. Consult your physician any time you have persistent pain with your exercise program.

## *Benefits*

Strength training will provide benefits to people of all ages with a minimal investment of time. Strength training exercises done for only 20 minutes twice a week may offer you the following benefits:

- Increased bone density
- Slowing of bone loss
- Improved balance and strength
- Decreased possibility of falls and fractures
- Reduction of body fat
- Increased energy
- Increased or maintained lean muscle mass
- Lower resting blood pressure
- Reduction of arthritic pain

Studies also show that people who do strength training are more self-confident and have a better body image. Increased body strength may also help you to perform your everyday activities with greater ease.

## *Possible Side Effects*

The most common side effect of strength training is muscle soreness. Sometimes soreness will occur immediately after you exercise; on other occasions it may not occur until one to two days later. It may last for three to four days. If persistent pain or soreness troubles you, contact your physician.

To prevent or limit muscle soreness, follow the guidelines in this information. Start slowly and plan to progress gradually in your strength training routine. Don't overdo it.

If you have swelling of a joint or can't move a joint through its full range of motion, see your physician.

# *Frequently-Asked Questions About Strength Training*

## *Will women get big muscles if they do strength training exercises?*

Strength training usually will help a woman become stronger and leaner but not overly muscular.

## *Isn't pumping iron just for body builders?*

Anyone can benefit from strength training. Strength training may offer you many benefits and protect your joints during your normal daily activities.

## *Will I gain weight?*

At first, you may gain a little weight because muscle weighs more than fat. However, muscle burns more calories than fat, so if you maintain the same diet, eventually you may lose some "fat" weight.

## *Is strength training safe for older adults?*

Strength training offers many benefits to older adults. Older adults who do strength training have a lower risk of hip fracture and reduced bone and muscle loss.

## *Will I need to buy a lot of equipment or go to a gym in order to have a successful strength training program?*

You can begin with 1-, 2- and 5-pound weights or even soup cans or milk bottles.

## *Do you recommend membership in a gym?*

It is not necessary to join a gym. Some people find it easier to be more consistent with their exercise in a gym or health club environment; some prefer to exercise at home.

A gym or health club may offer more opportunities to use equipment and machines that are not practical for home use. However, you can also do a good job at home using free weights and other forms of resistance, such as tubing.

## *Are injuries a problem with strength training?*

If it is correctly done, strength training should not cause injuries.

## *How much time do I need to spend exercising?*

You don't have to spend your whole afternoon exercising. Studies have shown that a 1-set program with a weight that causes fatigue of the muscle at the twelfth repetition can give you the same benefits in strength and muscle mass as a 3-set program. Just one set for the major muscle groups in the upper and lower body is enough to achieve significant gains in strength and muscle tone.

# *Strategies for Sticking to a Strength Training Program*

You will not realize benefits from an exercise program if you do not stick with it. There are some things you can do that may make your strength training program more enjoyable and easier to stay with:

- Choose a variety of activities that you enjoy.
- Start slowly. “No pain, no gain,” is not a healthy attitude; if exercises are painful, you are less likely to stay with the program and more likely to suffer an injury.
- Do your exercises at a time that is convenient for you.
- Exercise with a partner.
- Wear comfortable clothing.
- Choose an appropriate place in which you can exercise.
- Keep an exercise log; looking back at where you started can inspire you to keep on.

## *Word List*

**Fatigue** — The point at which you can no longer do repetitions of the exercise using the correct technique.

**Overload** — This occurs when greater than normal demand is placed on muscles.

**Repetition** — One complete cycle of a given weight training exercise.

**Sets** — A series of repetitions of a given weight training exercise performed continuously.

# *How to Use Your Exercise Log*

Column 1: This is the muscle group you are exercising with the name of the specific exercise. In the example “chest press,” you are exercising the chest muscles and doing the chest press.

Column 2: This is the setting on the machine you are using. The chest press machine has an adjustable seat, which is set on 4 in this example. Different machines may have different settings; you can note the settings you use in this column.

Day columns: Each day that you exercise, note the number of sets, pounds and repetitions that you do. In this example, on Tuesday, you did one set of the chest press at 35 lbs. You did 12 repetitions.

Each time you perform an exercise, write in the date, number of sets, weight used, and the number of repetitions. If you have questions about using your exercise log, ask your exercise specialist.

# Resistance Workout Form

Name (last): (first):		Set(s)/Llbs/Reps									
Exercise	(Machine) Adjust	Day Tues.	Day	Day	Day	Day	Day	Day	Day	Day	Day
Chest	Chest Press	4	1/35/12	/	/	/	/	/	/	/	/
		/	/	/	/	/	/	/	/	/	/
Back		/	/	/	/	/	/	/	/	/	/
		/	/	/	/	/	/	/	/	/	/
Legs		/	/	/	/	/	/	/	/	/	/
		/	/	/	/	/	/	/	/	/	/
Shoulders		/	/	/	/	/	/	/	/	/	/
		/	/	/	/	/	/	/	/	/	/
Biceps		/	/	/	/	/	/	/	/	/	/
		/	/	/	/	/	/	/	/	/	/
Triceps		/	/	/	/	/	/	/	/	/	/
		/	/	/	/	/	/	/	/	/	/
Abdomen		/	/	/	/	/	/	/	/	/	/
		/	/	/	/	/	/	/	/	/	/

# Resistance Workout Form

Name (last): (first):		Set(s)/Lbs/Reps										
Exercise	(Machine) Adjust	Day Tues.	Day	Day	Day	Day	Day	Day	Day	Day	Day	Day
Chest	Chest Press	/	/	/	/	/	/	/	/	/	/	/
		/	/	/	/	/	/	/	/	/	/	/
		/	/	/	/	/	/	/	/	/	/	/
Back		/	/	/	/	/	/	/	/	/	/	/
		/	/	/	/	/	/	/	/	/	/	/
		/	/	/	/	/	/	/	/	/	/	/
Legs		/	/	/	/	/	/	/	/	/	/	/
		/	/	/	/	/	/	/	/	/	/	/
		/	/	/	/	/	/	/	/	/	/	/
Shoulders		/	/	/	/	/	/	/	/	/	/	/
		/	/	/	/	/	/	/	/	/	/	/
		/	/	/	/	/	/	/	/	/	/	/
Biceps		/	/	/	/	/	/	/	/	/	/	/
		/	/	/	/	/	/	/	/	/	/	/
		/	/	/	/	/	/	/	/	/	/	/
Triceps		/	/	/	/	/	/	/	/	/	/	/
		/	/	/	/	/	/	/	/	/	/	/
		/	/	/	/	/	/	/	/	/	/	/
Abdomen		/	/	/	/	/	/	/	/	/	/	/
		/	/	/	/	/	/	/	/	/	/	/
		/	/	/	/	/	/	/	/	/	/	/



# Strength Training Exercises and Instructions

Included in this resource are illustrations and instructions for some strength training exercises. As you exercise, remember to follow the guidelines in this information so that you will have a successful strength training program.

In each illustration, the muscle group you are exercising is highlighted.

## **Chest press**

- Adjust the seat so the handles are at chest level.
- Push forward on the foot pedal so you can reach the handles easily.
- Release the foot pedal.
- Push your weight forward until your arms are extended but do not lock your elbows.
- Bring your weight back toward your chest until you feel a stretch across your shoulders.

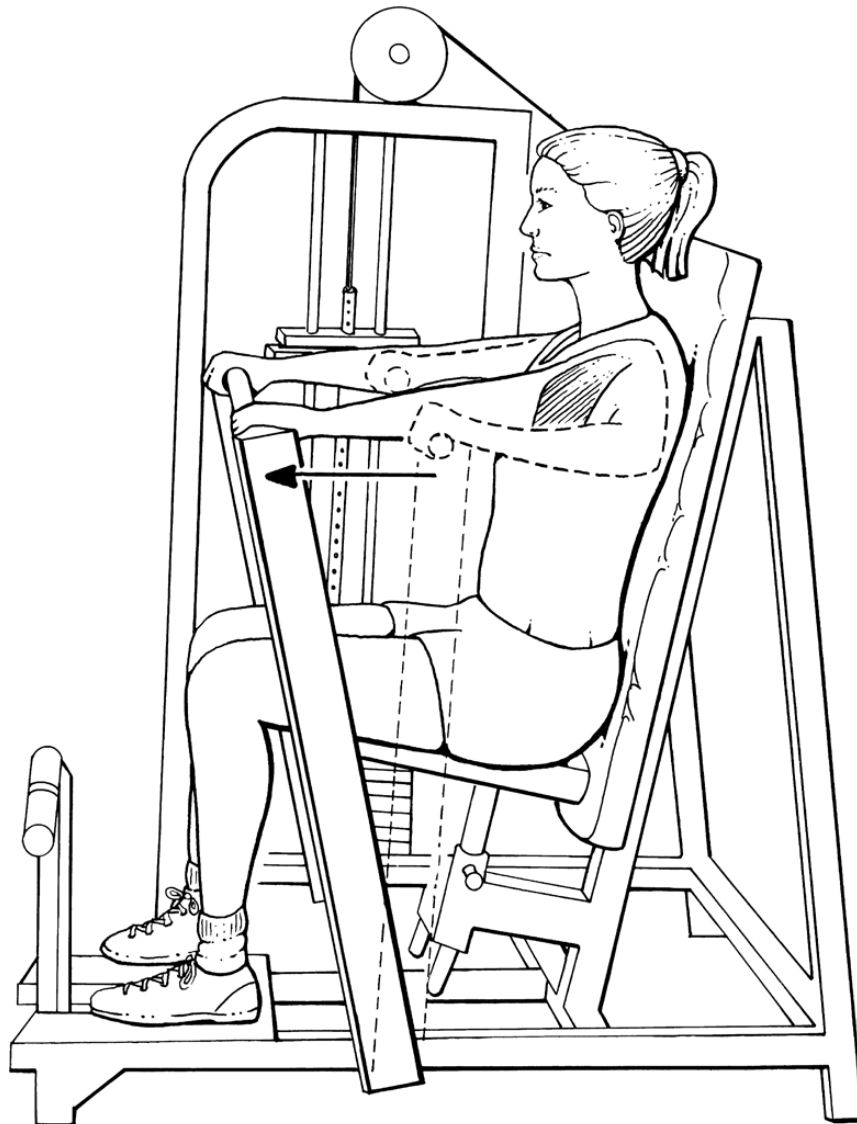

**Seated row**

- Adjust the machine so that you are just able to reach the handles.
- Adjust the seat so that the upright pad hits your body just below your chest level.
- Pull the handles back so that you bring your shoulder blades together.
- Return to your starting position.

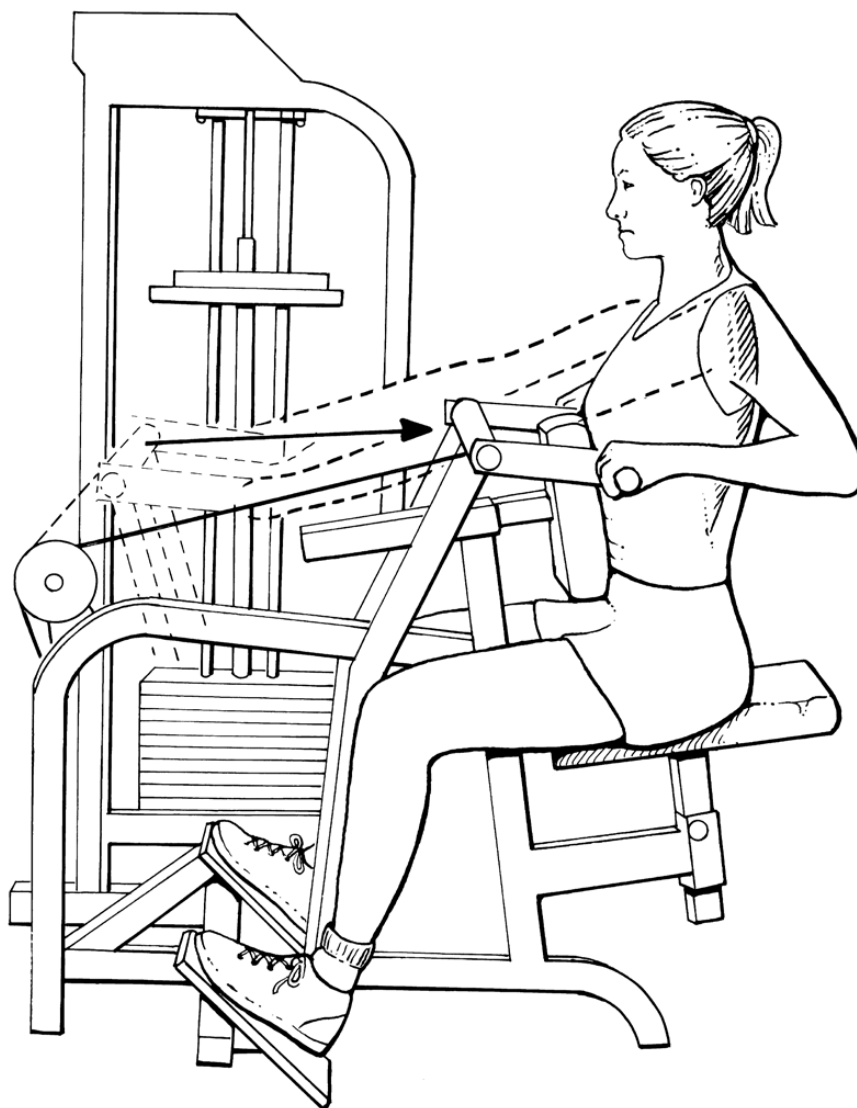

**Biceps curl**

- Stand with your feet shoulder width apart and your knees slightly bent.
- Hold the weights at your sides with your palms facing forward.
- Slowly lift the weights to your shoulders.
- Return to your starting position.



**Triceps pushdown**

- Stand with your feet shoulder width apart with your knees slightly bent.
- Hold the rope at waist level.
- Extend your forearms downward until your arms are extended.
- Keep your elbows at your sides throughout the exercise. Do not move your shoulders.
- Return to your starting position.

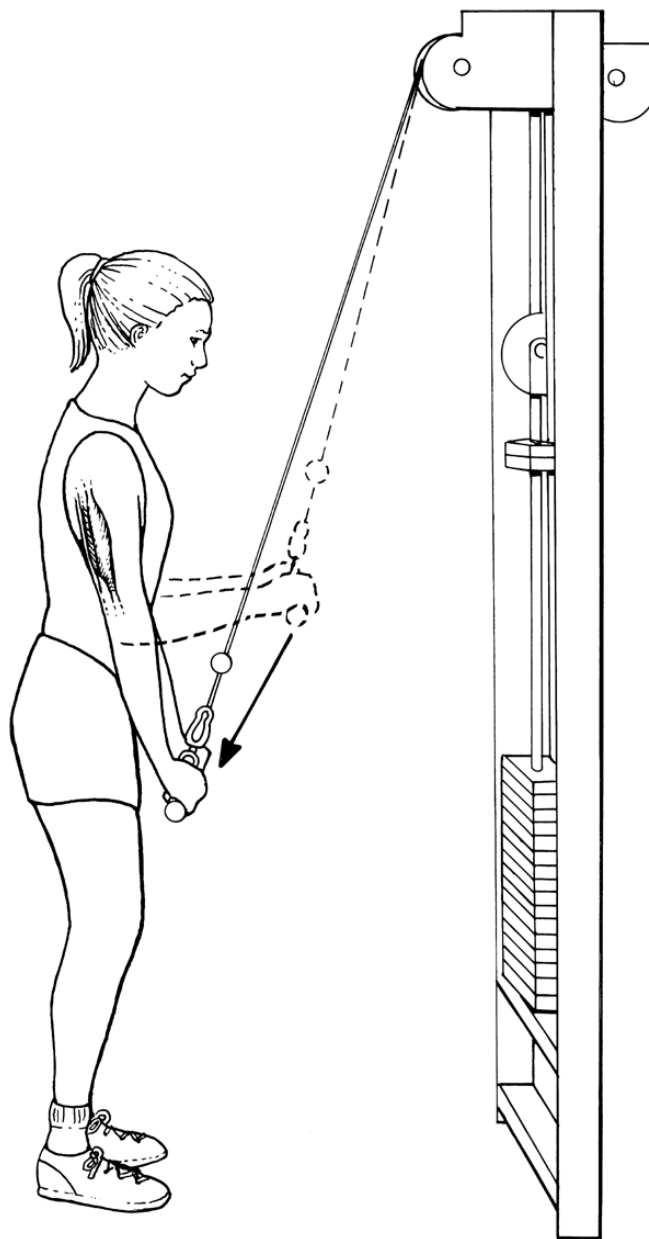

**Triceps extension**

- Lie flat on your back.
- Extend the arm holding the weight up toward the ceiling.
- Bend your elbow and slowly lower the weight towards your ear.
- Keep your upper arm still; your forearm is the only part of your arm that should move.

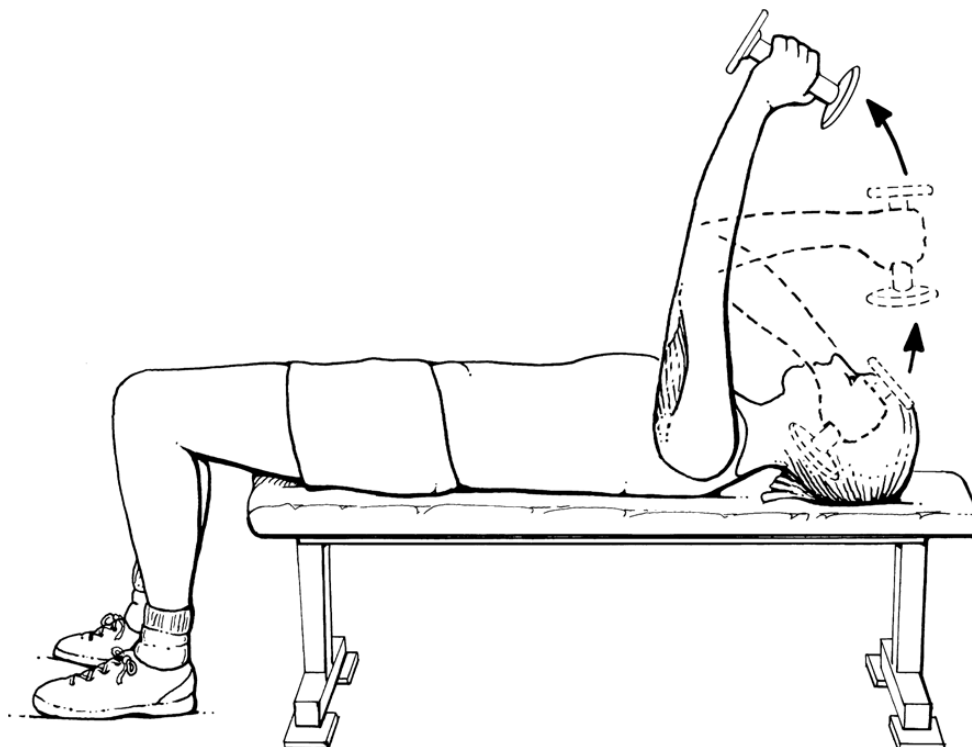

**Leg press**

- Place your feet shoulder width apart on the platform.
- Begin with your knees bent at slightly less than a 90 degree angle.
- Push away from the platform until your legs are almost fully extended.  
Do not lock your knees.
- Return to your starting position.

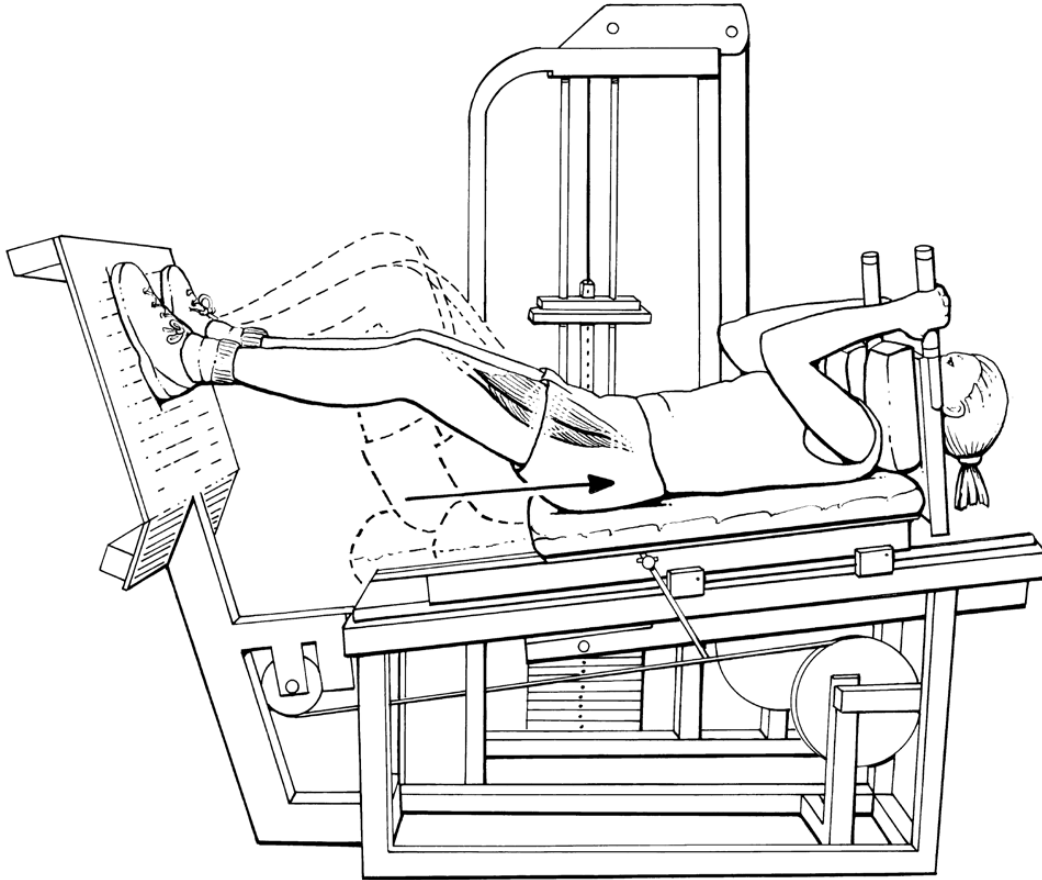

**Lying leg curl**

- Lie on the pad on your stomach. Adjust the roller bar to lay on the back of your ankles.
- Slowly bend your knees and bring your heels to your buttocks.
- Return to your starting position.
- Do **not** arch your back during the exercise.

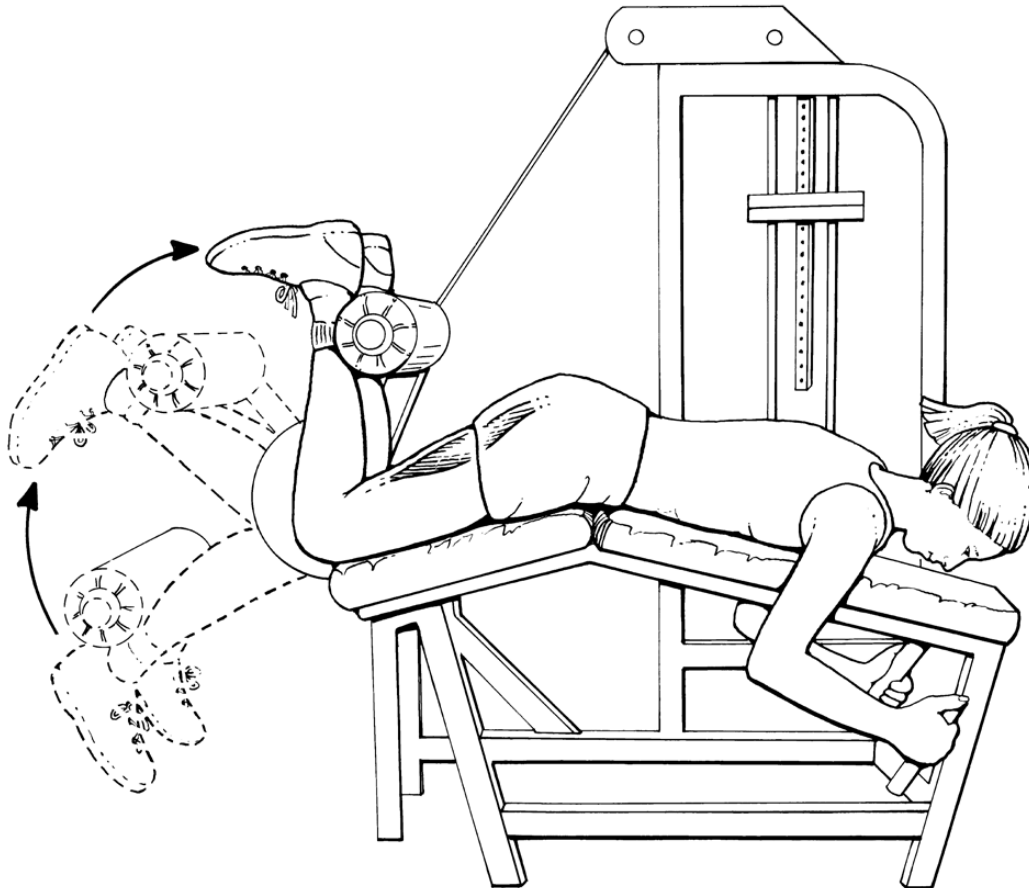

**Seated leg curl**

- Line up your knee with the pivot of the machine.
- Adjust the roll pad so that it hits the back of your ankles.
- Lower the thigh pad to the tops of your legs.
- Using your legs, pull back the weight as far under the seat as you can.
- Return to your starting position.

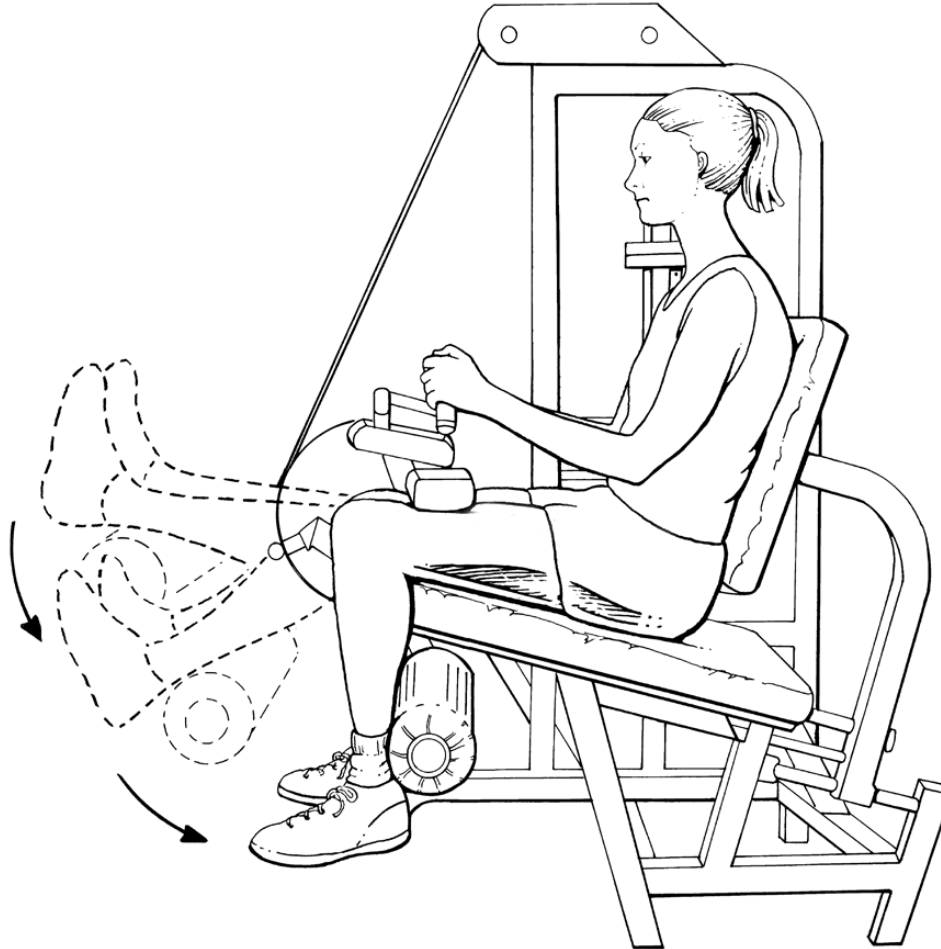



**Abdominal crunch**

- Lie on your back with your feet flat on the floor, knees bent.
- Clasp your hands behind your head. Keep your elbows back.
- Focus your eyes on the ceiling.
- Raise your upper body until your shoulder blades are off the floor.
- Return to your starting position.

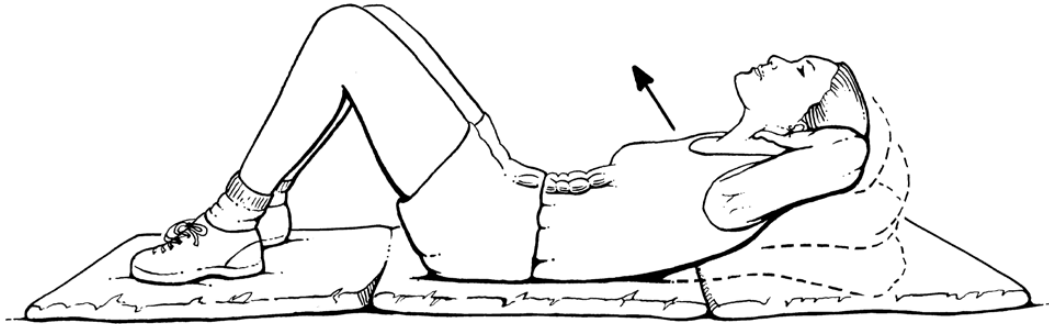
**Low back floor exercise**

- Lie on your stomach and extend your arms and legs.
- Raise the opposite arm and leg off the floor.
- Hold the position for a few seconds.
- Return to your starting position.

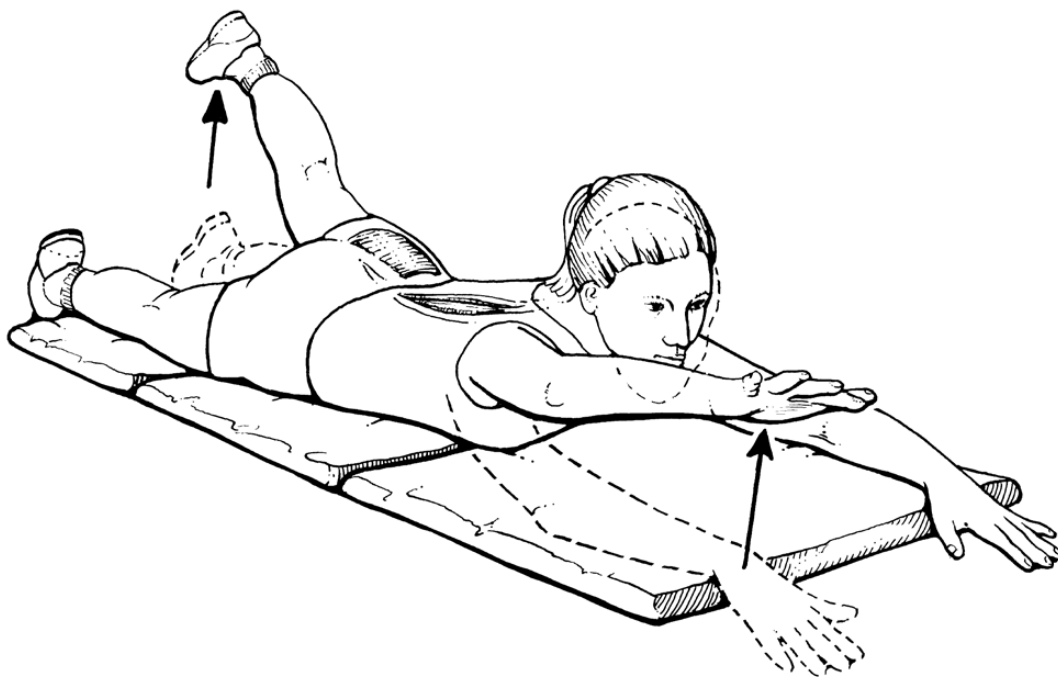

*This material is for your education and information only. This content does not replace medical advice, diagnosis or treatment. New medical research may change this information. If you have questions about a medical condition, always talk with your health care provider.*